



### POWER /ENERGY METER SINGLE PHASE AC/DC TRMS - RS485 MODBUS

QI-POWER-485-LV



<b>POWER SUPPLY</b>	9...30 Vdc, protection against polarity reversal and overtemperature.
<b>ABSORPTION</b>	< 1,3 W
<b>MEASUREMENT</b>	Irms, Vrms, Watt, Var, Va, Vpk, Ipk, Frequency, Cosφ, Energy bidirectional, THD, min e MAX of each measure
<b>TYPE OF MEASURE</b>	TRMS or DC
<b>RANGE</b>	<b>Current: up to 50 A AC/DC</b> <b>Voltage: up to 80 VAC or 100 VDC</b>
<b>ACCURACY</b>	@25 °C up to 200 Hz Voltage, Current, Active Power: < <b>0,5% F.S.</b> Frequency: ± <b>0,1 Hz</b> Energy: ± <b>1% of reading</b> Vpeak, Ipeak: ± <b>5% F.S.</b>
<b>OUTPUT</b>	RS485 Modbus RTU
<b>BAUDRATE</b>	From 1.200 a 115.200 baud
<b>CREST FACTOR</b>	1,8 (on current measurement)
<b>WORKING FREQUENCY</b>	DC or 1...400 Hz
<b>SAMPLING RATE</b>	11 k samples per second
<b>INPUT IMPEDENCE</b>	1 Mohm ± 1%
<b>STANDARDS CE</b>	EN61000-6-4/2006 + A1 2011; EN64000-6-2/2005; EN61010-1/2010
<b>OVERVOLTAGE CATEGORY</b>	Cat IV up to 100 V
<b>ISOLATION</b>	3 kV on bare wire for Current measure. 4 kV for Voltage measure (reinforced insulation to power supply and serial output)
<b>PROTECTION INDEX</b>	IP20
<b>TEMPERATURE COEFFICIENT</b>	< 200 ppm/°C
<b>WORKING TEMPERATURE</b>	-15...+65°C
<b>STORAGE TEMPERATURE</b>	-40°C... +85°C
<b>HUMIDITY</b>	10...90% not condensing
<b>ALTITUDE</b>	Up to 2000 m s.l.m.
<b>DIMENSIONS</b>	46,1 x 63 x 26,4 mm (terminal excluded)
<b>TERMINALS</b>	Removable terminals 3,5 mm, n°1 of 4 poles, n°2 of 2 poles
<b>WEIGHT</b>	80 g
<b>FILLING</b>	Epoxy resin
<b>BOX MATERIAL</b>	PBT, grey
<b>LED</b>	N°1 yellow, power on fixed, data communication blinking
<b>DIP-SWITCH</b>	2 poles
<b>MOUNTING</b>	Screw predisposition for vertical/horizontal mounting, DIN rail clips (included) for vertical/horizontal mounting.

The **QI-POWER-485-LV** is the **LOW VOLTAGE** version of the **Single-phase Power meter QI-POWER-485**, able to measure the RMS AC or DC Current and Voltage. On the RS485 Modbus are available: **Irms, Vrms, Watt, VAR, VA, Vpk, Ipk, Frequency, Cosφ, Energy bidirectional** and THD. The device is fully **configurable by RS485**, DIN rail mounting, 4kV galvanic isolation for Voltage input.

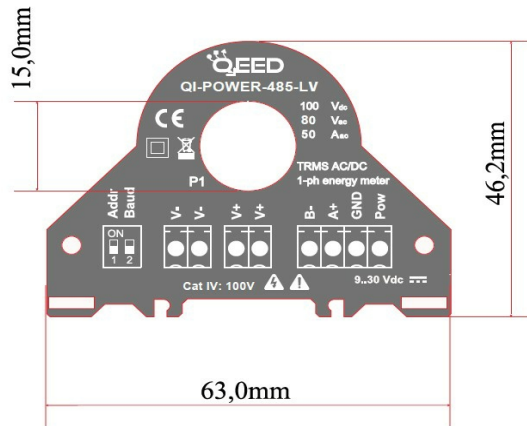

QI-POWER-485-LV

POWER/ENERGY METER SINGLE PHASE  
AC/DC TRMS - RS485 MODBUS

#### STRENGTHS:

- **LOW VOLTAGE VERSION;**
- TRMS Measure, THD available;
- 0,5 % Accuracy;
- RS485 Modbus integrated;
- Bidirectional energy metering;
- DIN rail mounting in both side;
- OEM'S design, low cost;
- Fully configurable by free interface software FACILE QI-POWER-485;
- Bootloader for updating firmware;
- Available measure register: MSW first LSW first or hundredts.





# INSTRUCTION MANUAL

# QI-POWER-485-LV

Using a serial link RS485-USB you can connect the QI-POWER-485-LV with the interface program FACILE QI-POWER-485. Using this software, allows you to set the Modbus address, baudrate, delay, the TV and TA ratio, to modify a filter in order to have fastest response time instead of a more stable measurement (filter range from 1-speed to 5-accuracy) and to measure frequency on current channel instead of voltage channel. You can download the FACILE QI-POWER-485 free of charge from our website [www.qeed.it](http://www.qeed.it) (section Products / Download Software).

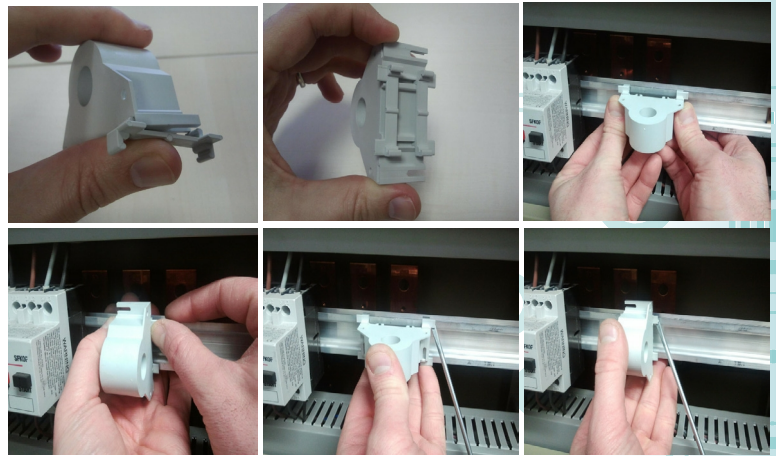

A second way to programming the QI-POWER-485-LV is by using the **Modbus Register Map** directly. Download it from our website: [www.qeed.it](http://www.qeed.it) (section Products / Download Software/ Facile QI-POWER-485 or section Products / Network Analyzers).

### MOUNTING:

the Power Meter QI-POWER-485-LV can be mounted in any position (see photo below), horizontal or vertical mounting, horizontal or vertical through the two.

### REMARKS:

- Modbus connections: A+ and B- as per Modbus RTU standards;
- Modbus Register reference: with reference to the logical address, for ex. 40010, corresponds to physical address n°9 as per Modbus RTU standard;
- Modbus functions supported: 3 (Read multiple registers, max 100), 6 (Write single), 16 (Write multiple);
- **Any changes made by dip-switch required to switch off the power supply or sending reset command.**

**Energy storage data on flash memory:** 4,5 years minimum, 45 years typical.  
**Minimum Current measurement (cut off):** 0 - 256 mA.  
**Minimum Power measurement (cut off):** 0 - 256 W.  
**Measurement refresh:** every 50 cycles or 1 second (the faster), programmable by FACILE.

If you want to set the device by FACILE QI-POWER-485 set the dips in 0. If you want to set by RS485 directly, set the first dip to 1 (up) then use the second dip for baudrate setting (0 for 9600 or 1 for 38400). After the settings, please save the configuration by the COMMAND register, then switch off the power supply, before to switch on the power supply set the DIPS in 0.

BAUDRATE SETTING	DIP 1	DIP 2
<b>All setting from EEPROM</b>	0	X
Set address 1 - 9600	1	0
Set address 1 - 38400	1	1

### FACILE QI-POWER-485

The free interface program FACILE QI-POWER-485 is the fastest way to configure the device. There is only one configuration screen (see picture shown). The changes made to the program act on the register of the QI-POWER-485-LV, if you want to restore the default configuration, just press the button FACTORY DEFAULT.

**TYPE OF MEASURE:** allows the selection of the measure RMS or DC only to define the sign, positive or negative, of reading.  
**SAVE ON ENERGY FLASH:** it is possible to activate the saving of the counters directly on the device's flash memory.

**REPORT OF TRANSFORMATION:** in case you would use the CT and / or VT, you can define the transformation ratio for the current input and voltage input, the default ratio is 1:1.

**FILTER:** allows you to insert a filter on reading in order to get more speed in responding (value 1) or a more stable and accurate measurement (value 5), by default the value is set to 2. You can choose between intermediate values already set or manually enter the desired filter by choosing the CUSTOM option from the menu, in this case, you can set the following parameters: *filtering in DC, filtering in AC (default value 5), Frequency measurement on Current channel.*

**MIN CURRENT THRESHOLD (mA):** Allow you to set the minimum current value (Cut off). Under this value the device measure Zero.

**MIN POWER THRESHOLD (W):** Allow you to set the minimum power value (Cut off). Under this value the device measure Zero.

**CAUTION:** magnetic fields of high intensity can vary the values measured by the transformer. Avoid installation near permanent magnets, electromagnets or iron masses that induce strong changes in the magnetic field. If any irregularity recommend reorient or move the transformer in the area most appropriate.

QI-POWER-485-LV

INSTRUCTION MANUAL

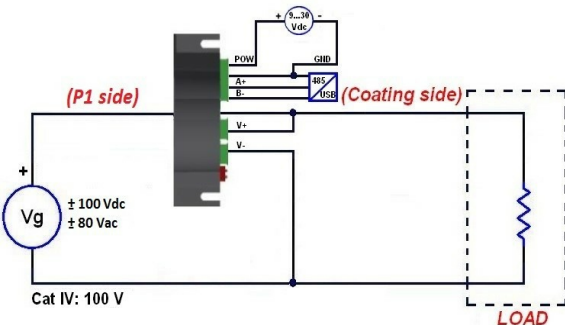

**!** The protection offered by the device can be compromised in the case that it isn't used in accordance with the instructions.

Disposal of Electrical & Electronic Equipment (Applicable throughout the European Union and other European countries with separate collection programs) This symbol, found on your product or on its packaging, indicates that this product should not be treated as household waste when you wish to dispose of it. Instead, it should be handed over to an applicable collection point for the recycling of electrical and electronic equipment. By ensuring this product is disposed of correctly, you will help prevent potential negative consequences to the environment and human health, which could otherwise be caused by inappropriate disposal of this product. The recycling of materials will help to conserve natural resources. For more detailed information about the recycling of this product, please contact your local city office, waste disposal service or the retail store where you purchased this product.

This document is the property of DEM S.p.A. Duplication or reproduction is prohibited. The contents of this document correspond to the products and technologies described. This information may be amended or supplemented by technical and commercial requirements.